

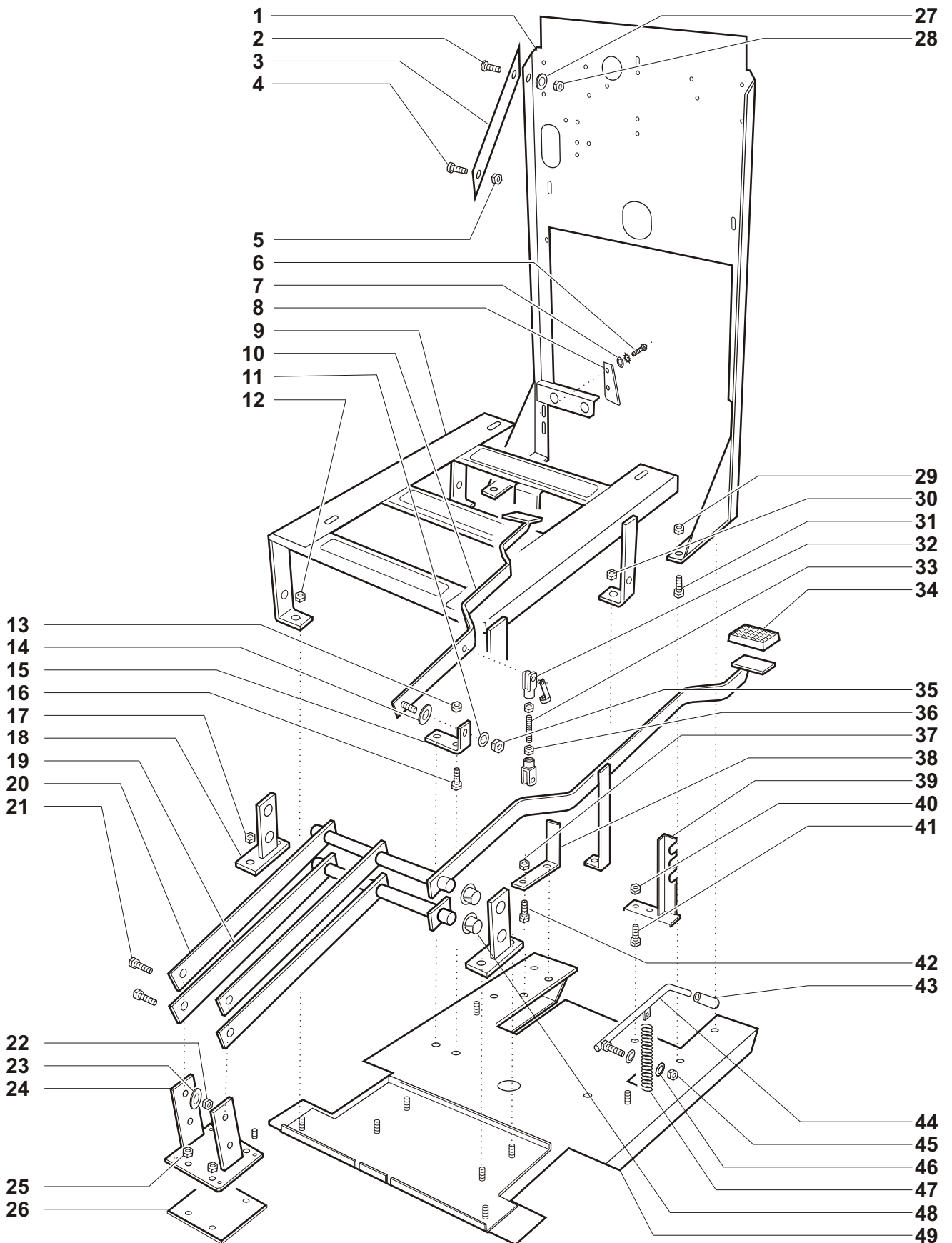

Pos.	Cod. n°	Descrizione	Description	Designation	Benennung	Denominacion
1	701.001	SCHIENALE	BACK FRAME	CHASSIS	RAHMEN	BASTIDOR
2	701.002	VITE	SCREW	VIS	SCHRAUBE	TORNILLO
3	700.003	STAFFA	YOKE	ETRIER	SPANNEISEN	ESTRIBO
4	701.004	VITE	SCREW	VIS	SCHRAUBE	TORNILLO
5	430.182	DADO	NUT	ECROU	MUTTER	TUERCA
6	430.065	VITE	SCREW	VIS	SCHRAUBE	TORNILLO
7	430.109	RONDELLA	WASHER	RONDELLE	UNTERLEGSSCHEIBE	ARANDELA
8	430.108	CAMMA	CAM	CAME	NOCKEN	CAMA
9	701.009	SUPPORTO	SUPPORT	SUPPORT	STÜTZE	SOPORTE
10	860.041	PEDALE	PEDAL	PEDALE	PEDAL	PEDAL
11	701.011	RONDELLA	WASHER	RONDELLE	UNTERLEGSSCHEIBE	ARANDELA
12	430.182	DADO	NUT	ECROU	MUTTER	TUERCA
13	430.182	DADO	NUT	ECROU	MUTTER	TUERCA
14	710.093	RONDELLA	WASHER	RONDELLE	UNTERLEGSSCHEIBE	ARANDELA
15	700.030	SQUADRETTA	BRACKET	SUPPORT	WINKEL	ESCUADRA
16	701.016	VITE	SCREW	VIS	SCHRAUBE	TORNILLO
17	430.182	DADO	NUT	ECROU	MUTTER	TUERCA
18	650.114	SUPPORTO	SUPPORT	SUPPORT	STÜTZE	SOPORTE
19	701.019	LEVA	LEVER	LEVIER	HEBEL	PALANCA
20	701.020	PEDALE	PEDAL	PEDALE	PEDAL	PEDAL
21	701.021	VITE	SCREW	VIS	SCHRAUBE	TORNILLO
22	850.310	DADO	NUT	ECROU	MUTTER	TUERCA
23	710.093	RONDELLA	WASHER	RONDELLE	UNTERLEGSSCHEIBE	ARANDELA
24	701.024	SUPPORTO	SUPPORT	SUPPORT	STÜTZE	SOPORTE
25	430.182	DADO	NUT	ECROU	MUTTER	TUERCA
26	700.084	PIASTRA	PLATE	PLAQUE	PLATTE	PLACA
27	701.027	RONDELLA	WASHER	RONDELLE	UNTERLEGSSCHEIBE	ARANDELA
28	701.028	DADO	NUT	ECROU	MUTTER	TUERCA
29	430.182	DADO	NUT	ECROU	MUTTER	TUERCA
30	430.182	DADO	NUT	ECROU	MUTTER	TUERCA
31	701.016	VITE	SCREW	VIS	SCHRAUBE	TORNILLO
32	500.120	FORCELLA	FORK	FOURCHE	GABEL	HORQUILLA
33	860.039	TIRANTE	TIE ROD	TIRANT	ZUGSTANGE	TIRANTE
34	500.154	COPRI PEDALE	PEDAL COVER	COUVRE PEDALE	PEDALKAPPE	CUBREPEDAL
35	850.310	DADO	NUT	ECROU	MUTTER	TUERCA
36	430.182	DADO	NUT	ECROU	MUTTER	TUERCA
37	430.182	DADO	NUT	ECROU	MUTTER	TUERCA
38	700.017	FERMO	STOP	ARRET	ANSCHLAG	TOPE
39	701.039	SQUADRETTA	BRACKET	SUPPORT	WINKEL	ESCUADRA
40	430.182	DADO	NUT	ECROU	MUTTER	TUERCA
41	701.016	VITE	SCREW	VIS	SCHRAUBE	TORNILLO
42	701.016	VITE	SCREW	VIS	SCHRAUBE	TORNILLO
43	701.043	MANIGLIA	HANDLE	POIGNÉE	GRIFF	MANIJA
44	701.044	LEVA	LEVER	LEVIER	HEBEL	PALANCA
45	850.310	DADO	NUT	ECROU	MUTTER	TUERCA
46	701.011	RONDELLA	WASHER	RONDELLE	UNTERLEGSSCHEIBE	ARANDELA
47	400.087	MOLLA	SPRING	RESSORT	FEDER	RESORTE
48	710.088	BOCCOLA	BUSHING	DOUILLE	BÜCHSE	BUJE
49	701.049	TELAIO	FRAME	CHASSIS	RAHMEN	BASTIDOR





Pos.	Cod. n°	Descrizione	Description	Designation	Benennung	Denominacion
100	430.066.B	MOTORIDUTTORE	MOTOR REDUCER	REDUCTEUR MOTEUR	REDUZIERER-MOTOR	REDUCTOR MOTOR
101	850.317	DADO	NUT	ECROU	MUTTER	TUERCA
102	500.023	RUOTA PARACOLPI	BUFFER WHEEL	ROUE BUTEE	PRELLRAD	RUEDA GUARDACHOQUES
103	701.103	DADO	NUT	ECROU	MUTTER	TUERCA
104	701.104	RONDELLA	WASHER	RONDELLE	UNTERLEGSSCHEIBE	ARANDELA
105	561.105	PIASTRA	PLATE	PLAQUE	PLATTE	PLACA
106	501.024	VITE	SCREW	VIS	SCHRAUBE	TORNILLO
107	701.028	DADO	NUT	ECROU	MUTTER	TUERCA
108	501.048	GANCIO	HOOK	CROCHET	HAKEN	GANCHO
109	500.019	PARASPRUZZI	SPLASH GUARD	ECRANT ANTI ECLABOUSSURES	SPRITZBLECH	FALDOM
110	550.115	LISTA PARASPRUZZI	SPLASH GUARD STRIP	BARRE ECRANT ANTI ECLABOUSSURES	LEISTE SPRITZBLECH	TOPE GUARDA SALPICONES
111	561.111	PIASTRA	PLATE	PLAQUE	PLATTE	PLACA
112	430.072	VITE	SCREW	VIS	SCHRAUBE	TORNILLO
113	430.176	VITE	SCREW	VIS	SCHRAUBE	TORNILLO
114	700.085	PIASTRA	PLATE	PLAQUE	PLATTE	PLACA
115	701.115	VITE	SCREW	VIS	SCHRAUBE	TORNILLO
116	510.130	GIUNTO	COUPLING	JOINT	KUPPLUNG	EMPALME
117	710.135	VITE	SCREW	VIS	SCHRAUBE	TORNILLO
118	701.118	VITE	SCREW	VIS	SCHRAUBE	TORNILLO
119	510.131	FLANGIA DX	FLANGE DX	BRIDE DX	FLANSCH DX	PESTAÑA DX
120	500.066	DADO	NUT	ECROU	MUTTER	TUERCA
121	850.306	VITE	SCREW	VIS	SCHRAUBE	TORNILLO
122	430.118	RONDELLA	WASHER	RONDELLE	UNTERLEGSSCHEIBE	ARANDELA
123	430.069.1	LINGUETTA	TANG	LANGUETTE	FEDERKEIL	LANGUETA
124	710.041	VITE	SCREW	VIS	SCHRAUBE	TORNILLO
125	550.088	SPAZZOLA	NYLON BRUSH	BROSSE EN NYLON	NYLONBURSTE	CEPILLO NYLON
125	550.089	SPAZZOLA TYNEX	TINEX BRUSH	BROSSE EN TINEX	TINEXBURSTE	CEPILLO TINEX
125	550.095	SPAZZOLA ACCIAIO	STEEL BRUSH	BROSSE EN ACIER	STAHLBURSTE	CEPILLO ACERO
125	550.096	SPAZZOLA VEGETALE	VEGETABLE BRUSH	BROSSE VEGETAL	VEGETALBURSTE	CEPILLO VEGETAL
125	550.097	TRASCINATORE	PAD HOLDER	ENTAINEMENT	MITNEHMER	CINTA DE ARRASTRE
125	550.098	DISCO ABRASIVO	ABRASIVE DISK	DISQUE ABRASIF	REIBE SCHALLPLATTE	DISCO ABRASIVO
126	510.132	FLANGIA SX	FLANGE SX	BRIDE SX	FLANSCH SX	PESTAÑA SX

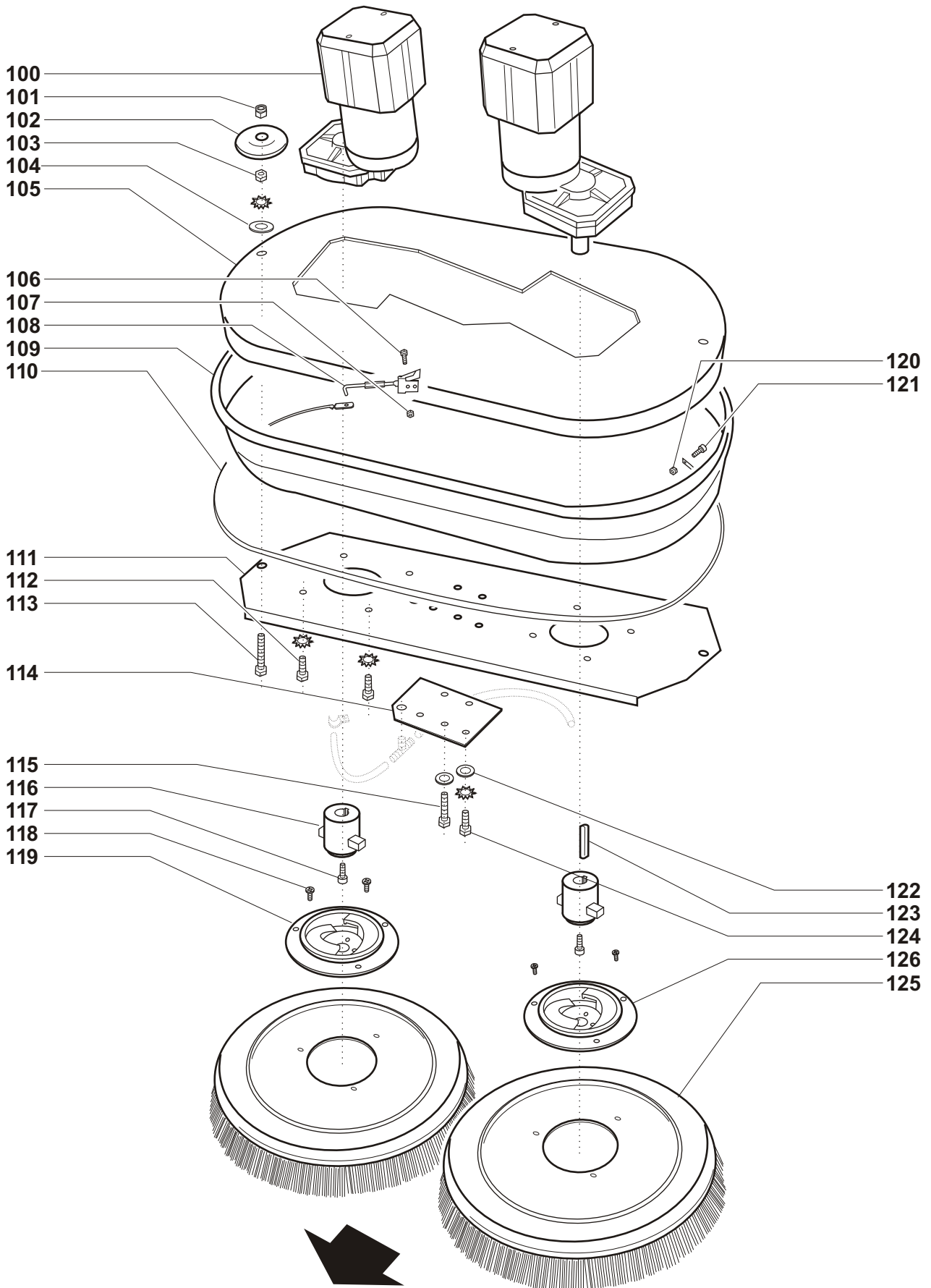



Pos.	Cod. n°	Descrizione	Description	Designation	Benennung	Denominacion
200	410.105.1	TIRANTE	TIE ROD	TIRANT	ZUGSTANGE	TIRANTE
201	430.070	RONDELLA	WASHER	RONDELLE	UNTERLEGSSCHEIBE	ARANDELA
202	700.101.1	PARATIA	SCREEN	PARAVENT	SCHIRM	MAMPARA
203	430.065	VITE	SCREW	VIS	SCHRAUBE	TORNILLO
204	701.204	RINFORZO	REINFORCE	RENFORCE	ICH STÄRKE	REFUERZO
205	700.131	SERBATOIO	TANK	RESERVOIR	BEHAELTER	TANQUE
206	430.182	DADO	NUT	ECROU	MUTTER	TUERCA
207	701.016	VITE	SCREW	VIS	SCHRAUBE	TORNILLO
208	400.040.1	ANELLO DI FERMO	LOCK RING	BAGUE D'ARRET	SICHERUNGSRING	ANILLO DE FIJACION
209	501.160	MANICOTTO	SLEEVE	MANCHON	HÜLSE	MANGUITO
210	500.257.3	MOTORE	MOTOR	MOTEUR	MOTOR	MOTOR
211	500.225	TUBO	PIPE	TUYAU	ROHR	TUBO
212	500.071	GUARNIZIONE	SEAL	JOINT	DICHTUNG	JUNTA
213	500.070	RETE (°)	NET	GRILLE	GITTER	RED
214	500.069	SPUGNA (°)	SPONGE	EPONGE	SCHWAMM	ESPONJA
215	500.068	SUPPORTO (*)	SUPPORT	SUPPORT	STÜTZE	SOPORTE
216	500.094	GALLEGGIANTE (°)	FLOAT LEVEL	FLOTTEUR	SCHWIMMER	FLOTADOR NIVEL
217	500.067	GUARNIZIONE (°)	SEAL	JOINT	DICHTUNG	JUNTA
218	850.257	TUBO	PIPE	TUYAU	ROHR	TUBO
219	430.194	VITE	SCREW	VIS	SCHRAUBE	TORNILLO
220	400.021	FERMATUBO	PIPE STRAPP	SERRE TUBE	ROHRHALTER	SUJETATUBO
221	400.031	TAPPO	PLUG	BOUCHON	VERSCHLUSS	TAPON
222	500.225	TUBO	PIPE	TUYAU	ROHR	TUBO
223	500.087.1	POMOLO	KNOB	POIGNEE	GRIFF	PUNO
224	500.085	RONDELLA	WASHER	RONDELLE	UNTERLEGSSCHEIBE	ARANDELA
225	500.078	GUARNIZIONE	SEAL	JOINT	DICHTUNG	JUNTA
226	500.079.1	FLANGIA FISSA	FIXED FLANGE	BRIDE FIXE	FESTER FLANSCH	BRIDA FIJO
227	500.083.1	GUARNIZIONE	SEAL	JOINT	DICHTUNG	JUNTA
228	710.270	FASCETTA	HOSE COLLOR	BANDE DE SERRAGE	SHELLE	BANDA
229	500.089.1	PORTAGOMMA	HOSE FITTING	EMBOUT POUR DURITE	GUMMITRAGER	PORTAMANGUERA
230	500.084.1	FLANGIA MOBILE	FLANGE	BRIDE	FLANSCH	BRIDA
231	510.205	MORSETTO	CLAMP	ETAU	ZWINGE	GRAPA
(°)	500.099	GALLEGG. COMPLETO	COMPLETE FLOAT	FLOTTEUR COMPLETE	SCHWIMMER VOLLSTANDIG	FLOTADOR DE NIVEL

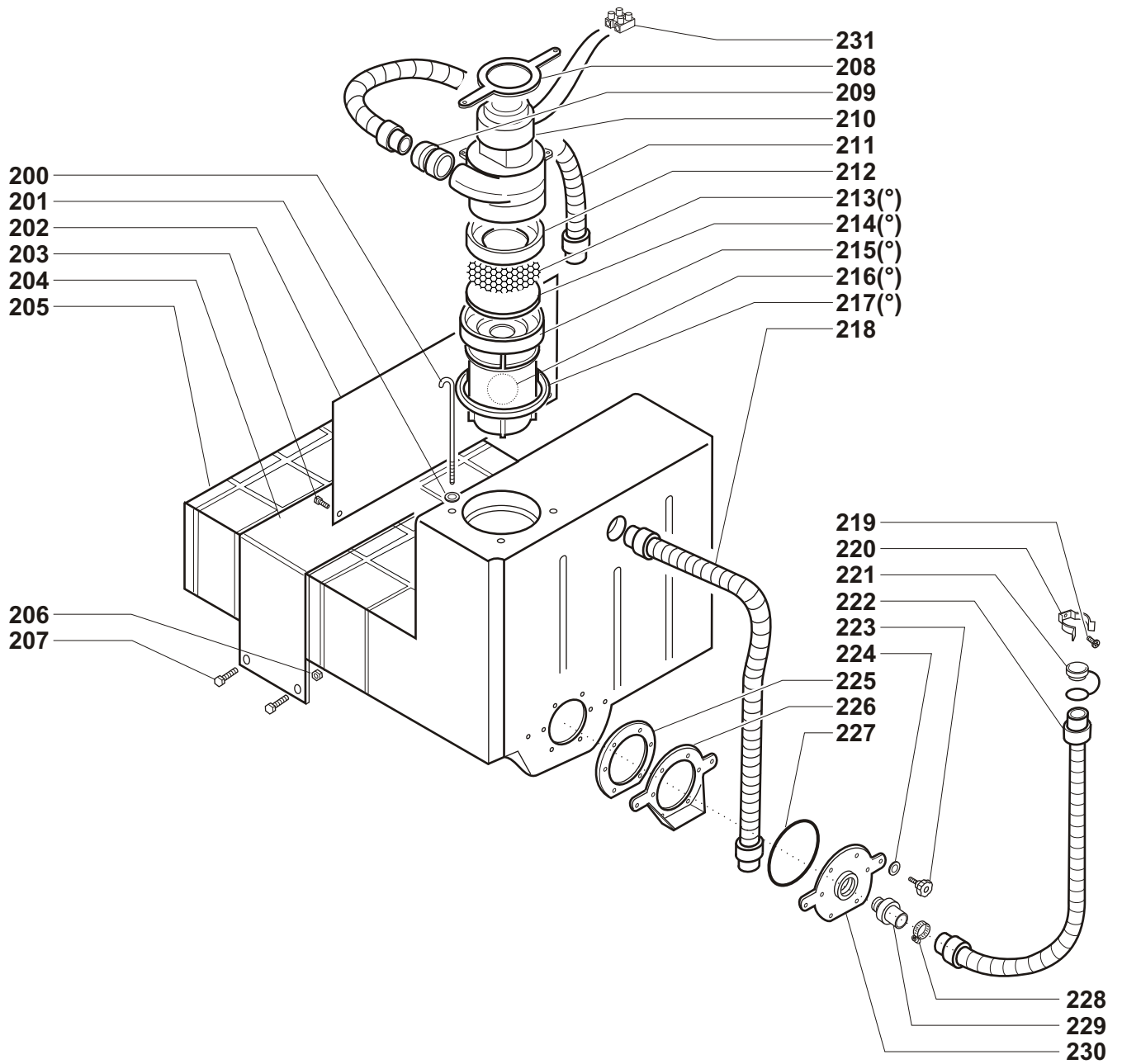



Pos.	Cod. n°	Descrizione	Description	Designation	Benennung	Denominacion
250	710.041	VITE	SCREW	VIS	SCHRAUBE	TORNILLO
251	430.118	RONDELLA	WASHER	RONDELLE	UNTERLEGSSCHEIBE	ARANDELA
252	701.210	CARENATURA	CHEST	COFFRE	HAUBE	COFRE
253	710.135	VITE	SCREW	VIS	SCHRAUBE	TORNILLO
254	710.088	BOCCOLA	BUSHING	DOUILLE	BÜCHSE	BUJE
255	700.044.1	LEVA	LEVER	LEVIER	HEBEL	PALANCA
256	700.045.2	SUPPORTO	SUPPORT	SUPPORT	STÜTZE	SOPORTE
257	400.087	MOLLA	SPRING	RESSORT	FEDER	RESORTE
258	400.087	MOLLA	SPRING	RESSORT	FEDER	RESORTE
259	700.047.2	LEVA	LEVER	LEVIER	HEBEL	PALANCA
260	701.260.1	TIRANTE	TIE ROD	TIRANT	ZUGSTANGE	TIRANTE
261	430.176	VITE	SCREW	VIS	SCHRAUBE	TORNILLO
262	550.178	LISTAANTERIORE	FRONT STRIP	BARRE AVANT	VORDERE LEISTE	TOPE ANTERIOR
263	550.179	GOMMA(*)	RUBBER	CAOUTCHOUC	GUMMI	GOMA
264	550.208	TERGIP. CORPO	SQUEEGEE BODY	CORPS NETTOYAGE	KOERPER FUSSBODE	CUERPO BOQUILLA
265	550.209.P	GOMMA PARA (*)	CREPE RUBBER	CAOUTCHOUC CREPE	PARA GUMMI	GOMA PARA
266	700.046	SUPPORTO	SUPPORT	SUPPORT	STÜTZE	SOPORTE
267	430.182	DADO	NUT	ECROU	MUTTER	TUERCA
268	500.222.1	REGOLATORE	REGULATOR	REGULATEUR	REGLER	REGULADOR
269	500.223.1	POMOLO	KNOB	POIGNEE	GRIFF	PUNO
270	700.042	RONDELLA NYLON	WASHER	RONDELLE	UNTERLEGSSCHEIBE	ARANDELA
271	710.168	VITE	SCREW	VIS	SCHRAUBE	TORNILLO
272	430.173	VITE	SCREW	VIS	SCHRAUBE	TORNILLO
273	500.023	RUOTA PARACOLPI	BUFFER WHEEL	ROUE BTEE	PRELLRAD	RUEDA GUARDACHOQUES
274	700.124	DADO	NUT	ECROU	MUTTER	TUERCA
275	710.165	VITE	SCREW	VIS	SCHRAUBE	TORNILLO
276	850.265	COPIGLIA	PLIT PIN	GOUPILLE	PLINT	CHAVETA
277	850.280	PERNO	PIN	GOUJON	BOLZEN	PERNO
278	500.226	FASCETTA	HOSE COLLOR	BANDE DE SERRAGE	SHELLE	BANDA
279	430.311	DADO	NUT	ECROU	MUTTER	TUERCA
280	710.178	DISTANZIALE	SPACER	ENTRETOISE	DISTANZSTÜCK	SEPARADOR
281	710.177	RUOTA	WHEEL	ROUE	RAD	RUEDA
282	710.176	VITE	SCREW	VIS	SCHRAUBE	TORNILLO
283	550.181	LISTAPOSTERIORE	BACK STRIP	BARRE POSTERIEUR	HINTER LEISTE	TOPE TRASERO
284						
285	710.175	SUPPORTO	SUPPORT	SUPPORT	STÜTZE	SOPORTE
286	501.286	CATENA	CHAIN	CHAÎNE	KETTE	CADENA

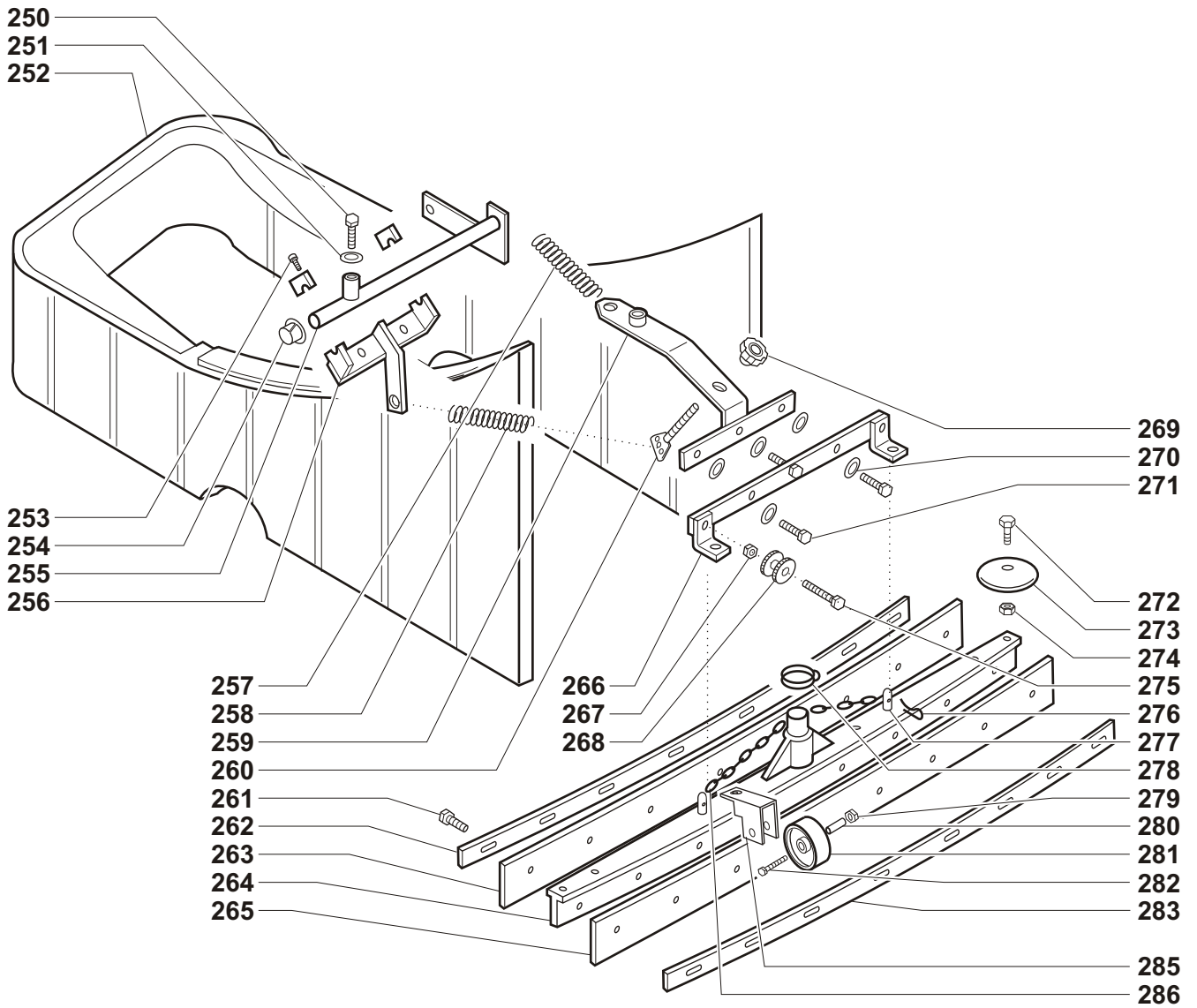



Pos.	Cod. n°	Descrizione	Description	Designation	Benennung	Denominacion
300	701.300	COPERCHIO	COVER	COUVERCLE	DECKEL	TAPA
301	700.136	SERBATOIO	TANK	RESERVOIR	BEHALTER	TANQUE
302	500.044	FILTRO	FILTER	FILTRE	FILTER	FILTRO
303	700.138	CERNIERA	HINGE	CHARNIERE	SCHARNIER	BISAGRA
304	700.142	ATTACCO RAPIDO	QUICK CONNECTOR	ATTAQUE RAPIDE	SCHNELLKUPPLUNG	ACOPLE RAPIDO
305	700.143	TUBO	PIPE	TUYAU	ROHR	TUBO
306	850.170	RACCORDO	JOINT	RACCORDEMENT	FERBINDE	EMPALME
307	700.139	TUBO	PIPE	TUYAU	ROHR	TUBO
308	700.141	TUBO	PIPE	TUYAU	ROHR	TUBO
309	700.142.1	ATTACCO RAPIDO	QUICK CONNECTOR	ATTAQUE RAPIDE	SCHNELLKUPPLUNG	ACOPLE RAPIDO
310	700.144	TUBO	PIPE	TUYAU	ROHR	TUBO
311	430.091	FASCETTA	HOSE COLLOR	BANDE DE SERRAGE	SHELLE	BANDA
312	400.161	DADO	NUT	ECROU	MUTTER	TUERCA
313	400.160.1	RUBINETTO	COCK	ROBINET	HAHN	GRIFO
314	430.078	DADO	NUT	ECROU	MUTTER	TUERCA
315	430.070	RONDELLA	WASHER	RONDELLE	UNTERLEGSSCHEIBE	ARANDELA
316	700.153	SUPPORTO	SUPPORT	SUPPORT	STÜTZE	SOPORTE
317	700.154	VITE	SCREW	VIS	SCHRAUBE	TORNILLO
318	700.155	VITE	SCREW	VIS	SCHRAUBE	TORNILLO
319	700.156	CERNIERA	HINGE	CHARNIERE	SCHARNIER	BISAGRA
320	700.158	SUPPORTO	SUPPORT	SUPPORT	STÜTZE	SOPORTE
321	430.056	VITE	SCREW	VIS	SCHRAUBE	TORNILLO
322	700.160	GANCIO	HOOK	CROCHET	HAKEN	GANCHO
323	500.061	POMOLO	KNOB	POIGNEE	GRIFF	PUNO
324	700.161	ASTA	ROD	TIGE	STANGE	BARRA
325	700.162.1	PANNELLO	PANEL	PANNEAU	PANEEL	PANEL
326	410.008	VITE	SCREW	VIS	SCHRAUBE	TORNILLO
327	430.182	DADO	NUT	ECROU	MUTTER	TUERCA
328	701.328	CRUSCOTTO	PANEL	PANNEAU	PANEEL	PANEL
329	500.054	VITE	SCREW	VIS	SCHRAUBE	TORNILLO
330	500.053	RONDELLA	WASHER	RONDELLE	UNTERLEGSSCHEIBE	ARANDELA
331	500.051	LEVA	LEVER	LEVIER	HEBEL	PALANCA
332	701.332	RACCORDO	JOINT	RACCORDEMENT	FERBINDE	EMPALME
333	510.053	COPERCHIO	COVER	COUVERCLE	BOLZEN	DECKEL
334	565.131	PORTA GOMMA	HOSE FITTING	EMBOUT	GUMMITRÄGER	PORTAMANGUERA
335	565.102	FERMA TUBO	PIPE SUPPORT	ARRÊTÉ TUYAU	ROHR AN	FIRME TUBO
336	700.138.1	SPESSORE CERNIERA	HINGE THICKNESS	ATTAQUE RAPIDE	GELENK DICKE	ESPEJOR BISAGRA

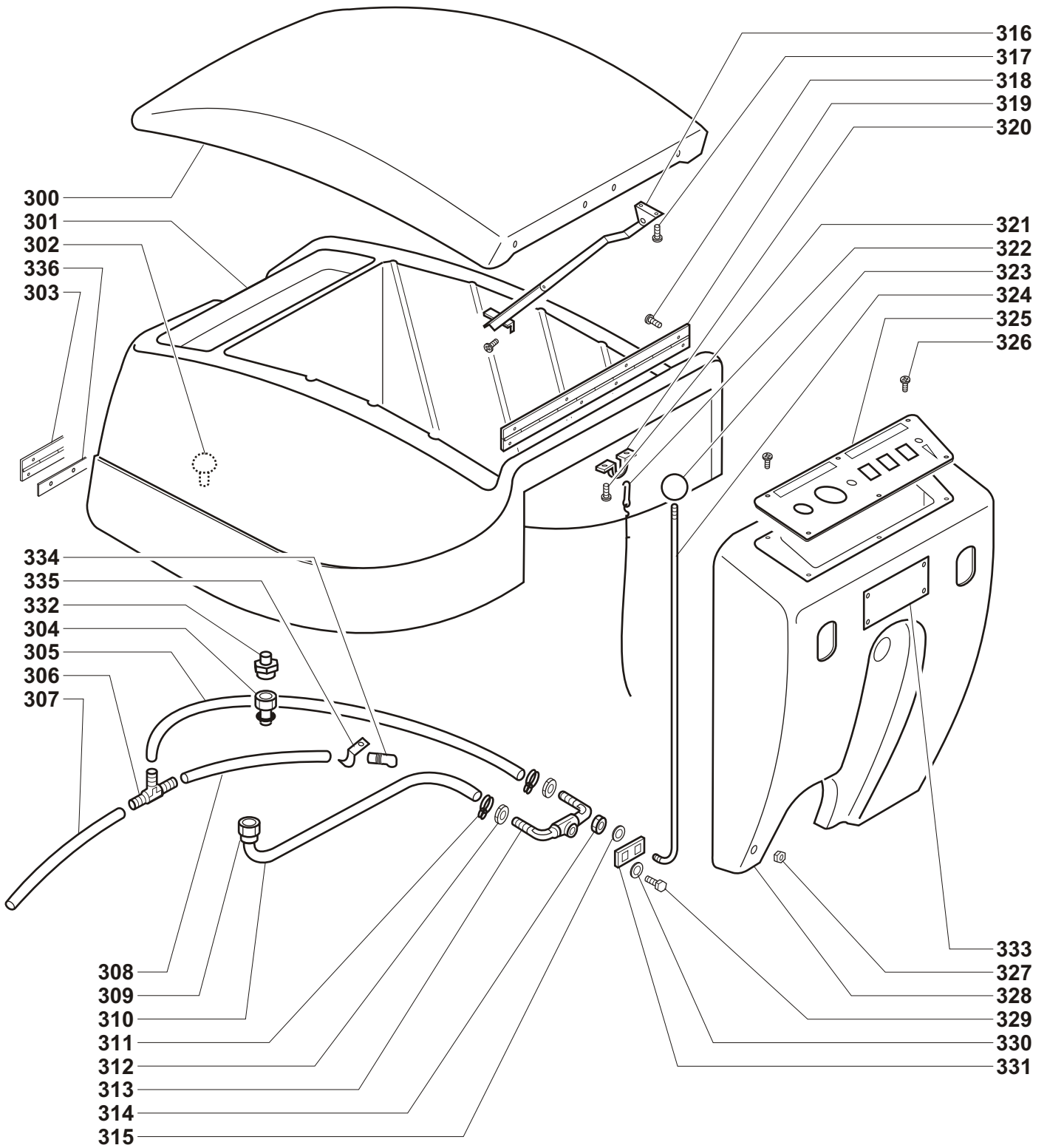



Pos.	Cod. n°	Descrizione	Description	Designation	Benennung	Denominacion
400	501.024	SOFFIETTO	BELLOW	SOUFFLET	GEBLASE	FUELLE
401	701.028	DADO	NUT	ECROU	MUTTER	TUERCA
402	701.027	RONDELLA	WASHER	RONDELLA	UNTERLEGSSCHEIBE	ARANDELA
403	501.048	GANCIO	HOOK	CROCHET	HAKEN	GANCHO
404	501.047	VITE	SCREW	VIS	SCHRAUBE	TORNILLO
405	701.405	RINFORZO	REINFORCE	RENFORCE	ICHSTÄRKE	REFUERZO
406	701.406	VITE	SCREW	VIS	SCHRAUBE	TORNILLO
407	500.032	VITE	SCREW	VIS	SCHRAUBE	TORNILLO
408	430.310	RONDELLA	WASHER	RONDELLA	UNTERLEGSSCHEIBE	ARANDELA
409	701.409	SQUADRETTA	SQUARE	EQUERRE	WINKEL	ESCUADRETA
410	430.120	VITE	SCREW	VIS	SCHRAUBE	TORNILLO
411	710.040	RONDELLA	WASHER	RONDELLA	UNTERLEGSSCHEIBE	ARANDELA
412	700.174	LEVA	LEVER	LEVIER	HEBEL	PALANCA
413	710.041	VITE	SCREW	VIS	SCHRAUBE	TORNILLO
414	430.118	RONDELLA	WASHER	RONDELLA	UNTERLEGSSCHEIBE	ARANDELA
415	501.028.1	SUPPORTO	SUPPORT	SUPPORT	STÜTZE	SOPORTE
416	430.182	DADO	NUT	ECROU	MUTTER	TUERCA
417	501.054	MANICO FINALE	HANDLE	MANCHE	GRIFF	MANGO
418	400.149	POMOLO	KNOB	POIGNEE	GRIFF	PUNO
419	501.055	SNODO	ARTICULATION	ARTICULATION	GELENK	ARTICULACION
420	430.323.3	MANICO	HANDLE	MACHE	GRIFF	MANGO
421	701.421	VITE	SCREW	VIS	SCHRAUBE	TORNILLO
422	701.422	DADO	NUT	ECROU	MUTTER	TUERCA
423	701.423	VITE	SCREW	VIS	SCHRAUBE	TORNILLO
424	500.066	DADO	NUT	ECROU	MUTTER	TUERCA
425	701.425	RONDELLA	WASHER	RONDELLA	UNTERLEGSSCHEIBE	ARANDELA
426	430.318.1	MICROINTERRUPTORE	MICROSWITCH	MNICROINTERRUPTEUR	MIKROSCHALTER	MICROINTERRUPTOR
427	700.194	DISTANZIALE	SPACER	ENTRETOISE	DISTANZSTÜCK	SEPARADOR
428						
429	701.425	RONDELLA	WASHER	RONDELLA	UNTERLEGSSCHEIBE	ARANDELA
430	430.194	VITE	SCREW	VIS	SCHRAUBE	TORNILLO
431	501.141	MOLLA	SPRING	RESSORT	FEDER	RESORTE
432	430.160	GRANO	DOWEL	GOUJON	ZAPFEN	GRANO

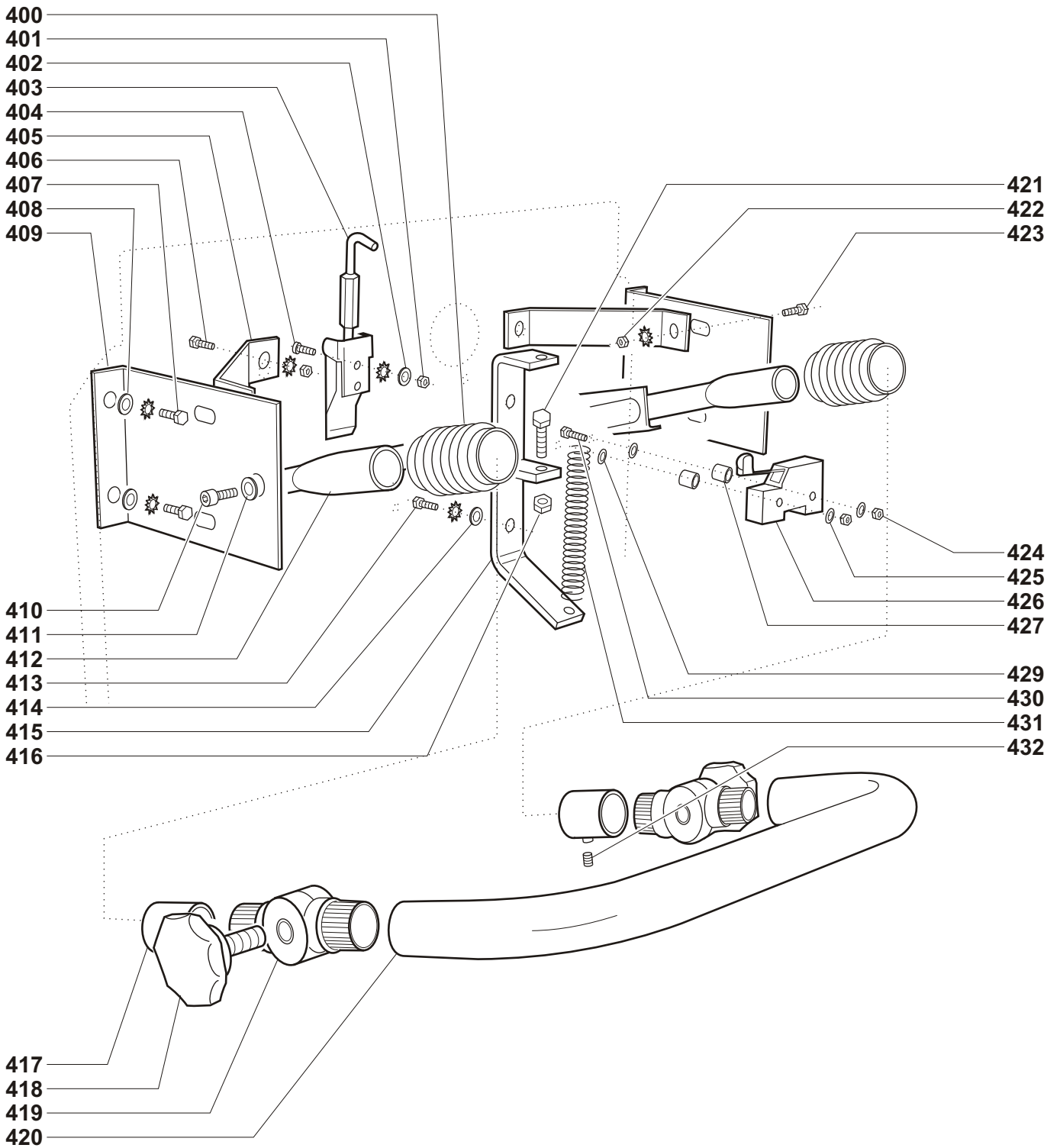



Pos.	Cod. n°	Descrizione	Description	Designation	Benennung	Denominacion
500	701.500	MOTO DIFFERENZIALE	MOTO DIFFERENTIAL	MOTEUR DIFFÉRENTIEL	DIFFERENTIAL MOTOR	MOTOR DIFERENCIAL
501						
502	710.040	RONDELLA	WASHER	RONDELLE	UNTERLEGSSCHEIBE	ARANDELA
503	701.503	LEVA	LEVER	LEVIER	HEBEL	PALANCA
504	500.204.2	RUOTA PIVOTTANTE	SWIVEL WHEEL	ROULETTE A TIGE	LENKROLLE	RUEDECILLAS
505	701.016	VITE	SCREW	VIS	SCHRAUBE	TORNILLO
506	430.182	DADO	NUT	ECROU	MUTTER	TUERCA
507	430.182	DADO	NUT	ECROU	MUTTER	TUERCA
508	701.508	VITE	SCREW	VIS	SCHRAUBE	TORNILLO
509	430.182	DADO	NUT	ECROU	MUTTER	TUERCA
510	710.040	RONDELLA	WASHER	RONDELLE	UNTERLEGSSCHEIBE	ARANDELA
511	410.052	CAMMA	CAM	CAME	NOCKEN	CAMA
512	701.512	VITE	SCREW	VIS	SCHRAUBE	TORNILLO
513	501.248	CUSCINETTO	BEARING	BEARING	LAGER	RODAMIENTOS
514	501.246	GUARNIZIONE	SEAL	JOINT	DICHTUNG	JUNTA
515	701.115	VITE	SCREW	VIS	SCHRAUBE	TORNILLO
516	510.011	STAFFA	YOKE	ETRIER	SPANNEISEN	ESTRIBO
517	701.517	FRENO ELETTRICO	ELECTRIC BRAKE	FREIN ÉLECTRIQUE	ICH BREMSE ELEKTRISCH	FRENO ELÉCTRICO
518	501.236	LINGUETTA	TANG	LANGUETTE	FEDERKEIL	LANGUETA
519	510.249	ANELLO RASAMENTO	RING	ANNEAU	RING	ANILLO
520	510.248	SEEGER	SEEGER RING	SEEGER ANNEAU	SEEGER RING	ANILLO SEEGER
521	701.521	RUOTA	WHEEL	ROUE	RAD	RUEDA
522	510.249	ANELLO RASAMENTO	RING	ANNEAU	RING	ANILLO
523	701.523	GHIERA	RING NUT	EMBOUT	DER RING	ABRAZADERA
524	430.182	DADO	NUT	ECROU	MUTTER	TUERCA
525						
526	430.182	DADO	NUT	ECROU	MUTTER	TUERCA
527						
528	701.528	VITE	SCREW	VIS	SCHRAUBE	TORNILLO
529	430.310	RONDELLA	WASHER	RONDELLE	UNTERLEGSSCHEIBE	ARANDELA
530	701.500.1	MOTORE	MOTOR	MOTEUR	MOTOR	MOTOR

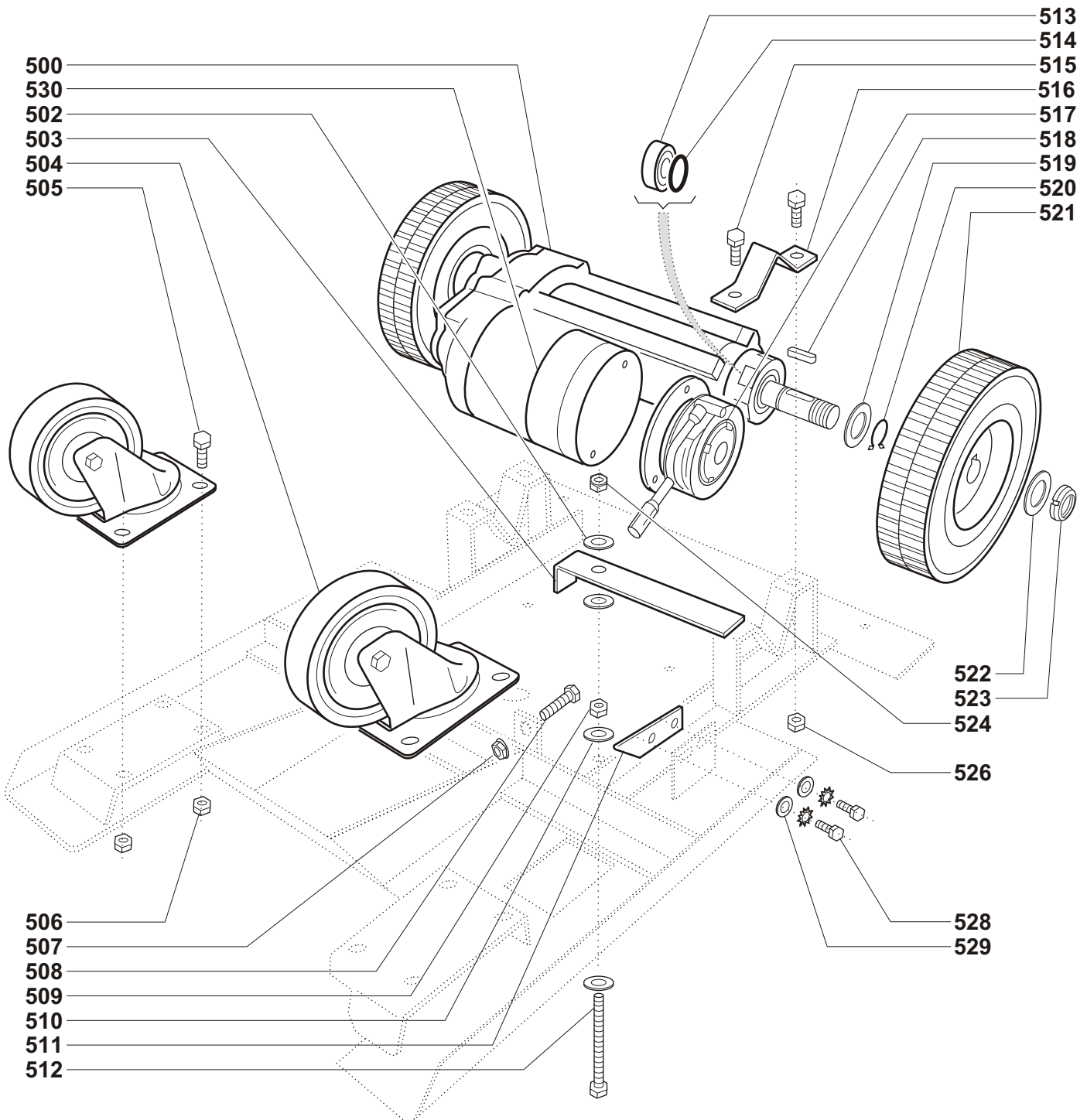



Pos.	Cod. n°	Descrizione	Description	Designation	Benennung	Denominacion
600	700.220	VASCA	VAT	CUVE	WANNE	CUBA
601	850.393	FUSIBILE	FUSE	FUSIBILE	SICHERUNG	FUSIBLE
602	510.330.1	SCHEDA ELETTRONICA	ELECTRONIC CARD	CARTE ELECTRONIQUE	ELEKTRONISKE KARTE	TARJETA ELECTRONICA
603	700.231	FUSIBILE	FUSE	FUSIBILE	SICHERUNG	FUSIBLE
604	850.423	FUSIBILE	FUSE	FUSIBILE	SICHERUNG	FUSIBLE
605	850.423	FUSIBILE	FUSE	FUSIBILE	SICHERUNG	FUSIBLE
606	850.423	FUSIBILE	FUSE	FUSIBILE	SICHERUNG	FUSIBLE
607	500.262	CAVO	CABLE	FIL	KABEL	CABLE
608	500.250.1	BATTERIA TUBOLARE 240 Ah	HOSE BATTERY 240Ah	BATTERIE TUYAU 240 Ah	ROHR BATTERIE 240 Ah	BATERIA MANGUERA 240 Ah
608	500.250.2	BATTERIA CORAZZATA 240 Ah	ARMATURE BATTERY 240Ah	BATTERIE ARMATURE 240 Ah	ANKER BATTERIE 240 Ah	BATERIA ARMADA 240 Ah
608	500.250.3	BATTERIA PIANA 240 Ah	PLATE BATTERY 240Ah	ANKER PLAQUE 240 Ah	PLATTE BATTERIE 240 Ah	BATERIA PLACA 240 Ah
608	700.227	BATTERIA TUBOLARE 280 Ah	HOSE BATTERY 280Ah	BATTERIE TUYAU 280 Ah	ROHR BATTERIE 280 Ah	BATERIA MANGUERA 280 Ah
609	500.263	CAVO (-)	CABLE (-)	FIL (-)	KABEL (-)	CABLE (-)
610	500.266	CAVO (+)	CABLE (+)	FIL (+)	KABEL (+)	CABLE (+)
611	500.258.1	CONNETTORE	CONNECTION	CONNECTEUR	ANSCHLUSS	CONNECTOR
612	500.258.1	CONNETTORE	CONNECTION	CONNECTEUR	ANSCHLUSS	CONNECTOR
613	430.299	VITE	SCREW	VIS	SCHRAUBE	TORNILLO
614	430.297	RONDELLA	WASHER	RONDELLE	UNTERLEGSSCHEIBE	ARANDELA
615	430.296	DADO	NUT	ECROU	MUTTER	TUERCA
616	650.328	STAFFA	YOKE	ETRIER	SPANNEISEN	ESTRIBO
617	430.072	VITE	SCREW	VIS	SCHRAUBE	TORNILLO
618	430.078	DADO	NUT	ECROU	MUTTER	TUERCA
619	430.310	RONDELLA	WASHER	RONDELLE	UNTERLEGSSCHEIBE	ARANDELA
620	430.293	TELERUTTORE	REMOTE CONTROL	TELERUPTEUR	FERNSCHALTER	TELEINTERRUPTOR
621	701.621	DADO	NUT	ECROU	MUTTER	TUERCA
622	510.332	PULSANTE RETROMARCIA	REVERSE RUNNING BUTTON	BOUTON MARCHE ARRIERE	KNOPF RÜCKWÄRTSGANG	BOTON MARCHA ATRAS
623	430.302	INTERRUTTORE	SWITCH	INTERRUPTEUR	SCHALTER	INTERRUPTOR
624	430.302	INTERRUTTORE	SWITCH	INTERRUPTEUR	SCHALTER	INTERRUPTOR
625	430.300	MANOPOLA	KNOB	HANDLE	GRIFF	MANDO
626	850.472	POTENZIOMETRO	POTENTIOMETER	POTENTIOMETRE	POTENTIOMETER	POTENCIOMETRO
627	500.251	INDICATORE BATTERIA	BATTERY INDICATOR	INDICATEUR BATTERIE	SKALERING BATTERIE	INDICADOR BATERIA
628	850.416	INTERRUTTORE A CHIAVE	KEY SWITCH	INTERRUPTEUR A CLE	SCHLÜSSEL SCHALTER	INTERRUPTOR LLAVE
629	701.629	PORTA FUSIBILE	FUSE HOLDER	PORTE FUSIBLE	ES DOST SICHERUNG	CAJA FUSIBLE
(°)	701.630.B	IMPIANTO ELETTRICO	WIRING	CABLAGE	VERKABELUNG	CABLEADO
630	701.630	BASSETTA FUSIBILI	FUSE SOCKET	PATTE DE FUSIBLES	KOTELETTE SICHERUNGEN	PATILLA FUSIBLES
631	430.066.B	MOTORIDUTTORE	MOTOR REDUCER	REDUCTEUR MOTEUR	REDUZIERER-MOTOR	REDUCTOR MOTOR
632	430.066.B	MOTORIDUTTORE	MOTOR REDUCER	REDUCTEUR MOTEUR	REDUZIERER-MOTOR	REDUCTOR MOTOR
633	500.257.3	MOTORE	MOTOR	MOTEUR	MOTOR	MOTOR
634	701.500	MOTO DIFFERENZIALE	MOTO DIFFERENTIAL	MOTEUR DIFFÉRENTIEL	DIFFERENTIAL MOTOR	MOTOR DIFERENCIAL
635	430.318.1	MICROINTERRUTTORE	MICROSWITCH	MICROINTERRUPTEUR	MIKROSCHALTER	MICROINTERRUPTOR
636	701.636	DISTANZIALE	SPACER	ENTRETOISE	DISTANZSTÜCK	SEPARADOR

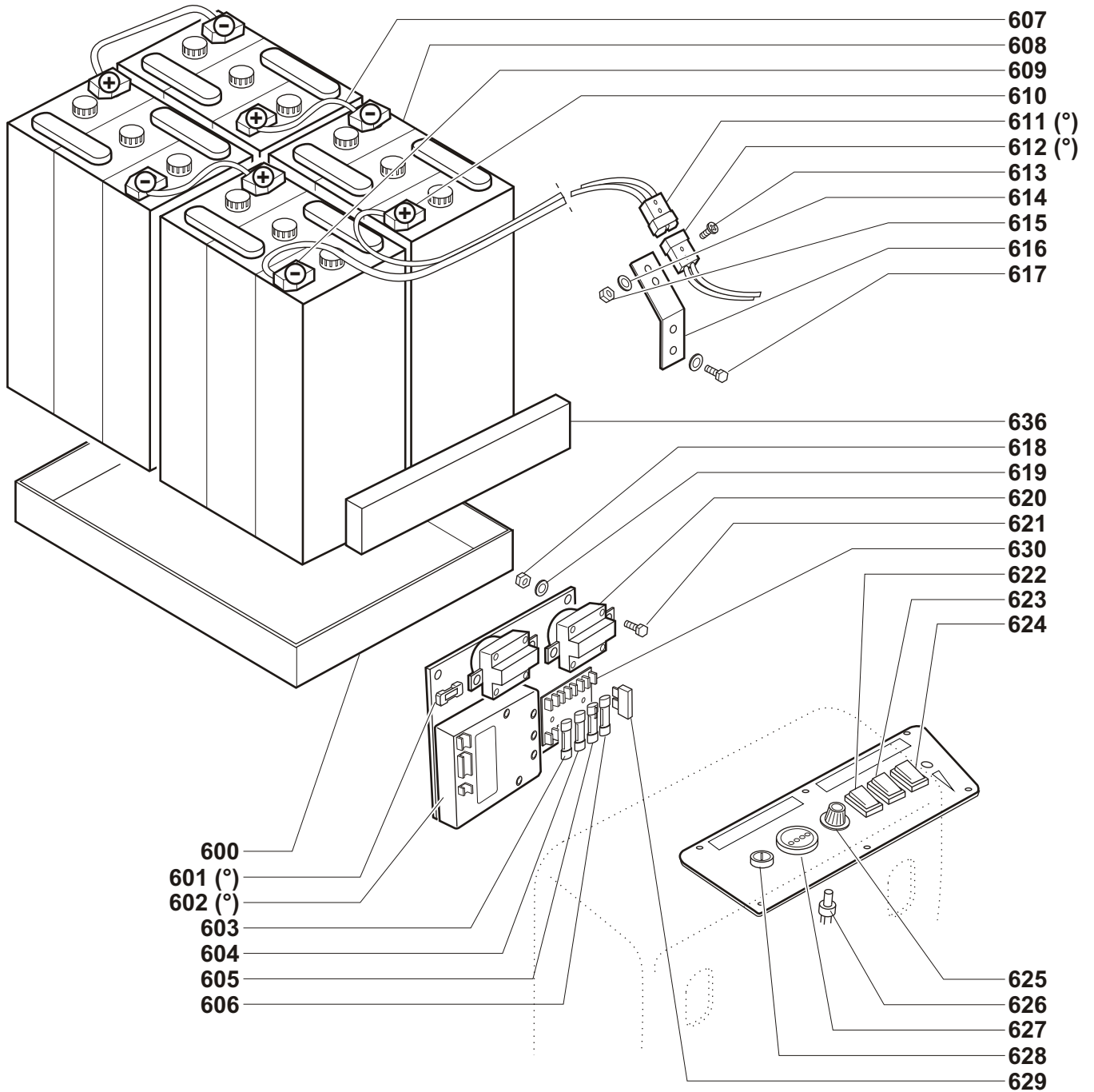

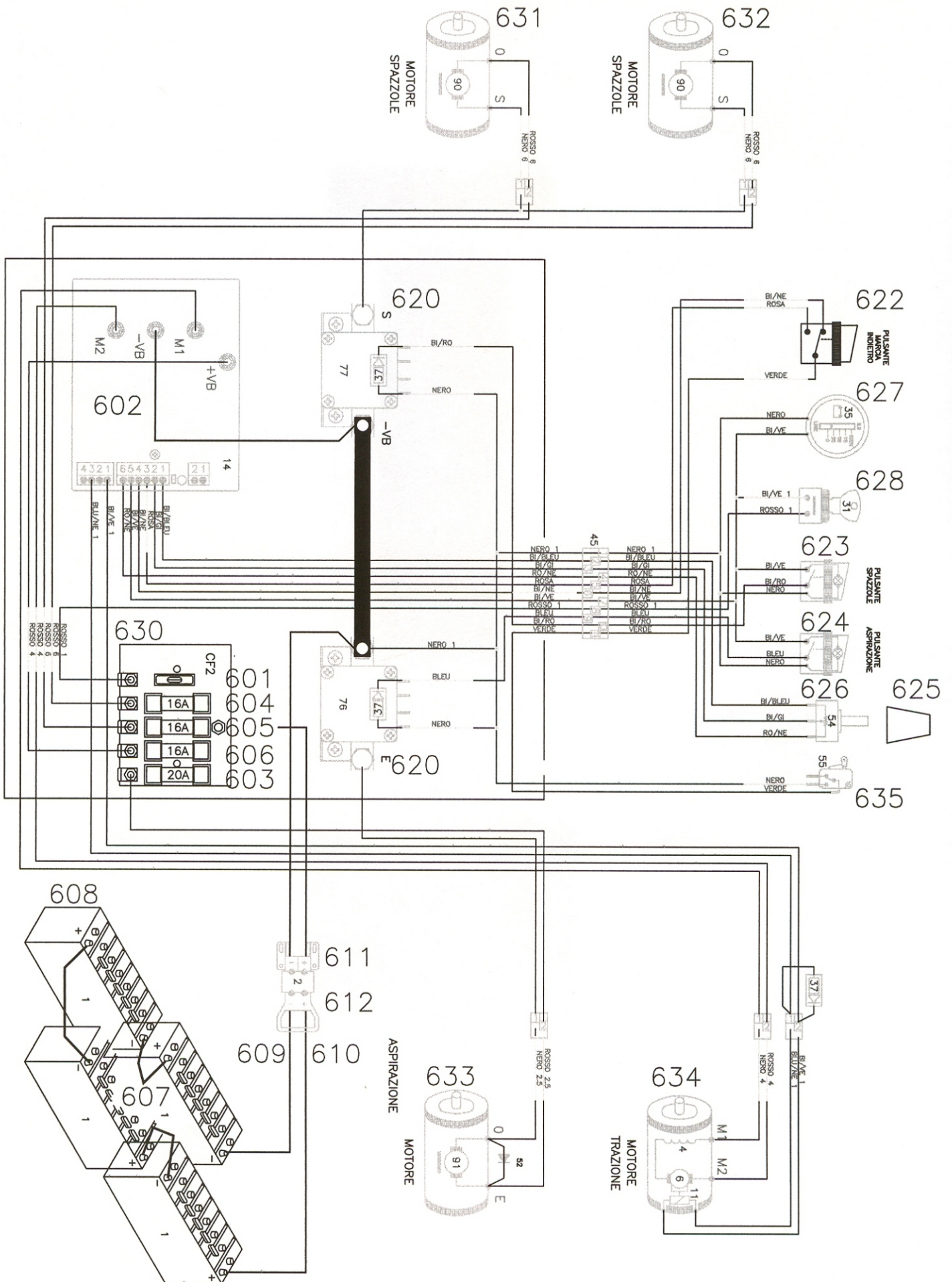



NORME DI SICUREZZA BATTERIE. Occorre ricordare sempre che le batterie generano gas che possono provocare esplosioni se vengono in contatto con fiamme e scintille. Non eseguire mai riparazioni su una batteria che e' in carica. Non appoggiare utensili o parti metalliche sopra la batteria. Mantenere pulite ed asciutte le batterie; i collegamenti dovranno essere ricoperti con grasso antiacido o vasellina. Aver cura che la vaschetta di contenimento sia mantenuta pulita.

NORMS FOR BATTERIES SAFETY. It is necessary to remember that the batteries produce gas that can provoke explosions if they come in contact with flames and sparks. Do not perform repairs on a battery while it's recharging. Don't leave tools or metallic parts on the battery. Always clean up and dry the batteries; the connections must be covered with anti-acid grease or petroleum jelly. Take care that the battery tank is always cleaned.

RÈGLES DE SÛRETÉ BATTERIES. Il faut rappeler toujours que les batteries engendrent gaz qu'ils peuvent provoquer explosions si ils viennent en contact avec des flammes et étincelles. Ne pas exécuter jamais réparations sur une batterie qu'et en charge. Ne pas appuyer outils ou parties métalliques sur la batterie. Maintenir coups de torchon et sèches les batteries; les liaisons dus été recouvert avec antiacide gras ou vaseline. Avoir soin qu'elle vaschet-à de limitation coup de torchon soit maintenu.

N O R M E N S I C H E R H E I T S B A T T E R I E N . Es ist notwendig immer zu erinnern, daß die Batterien Gas zeugen, daß sie Explosionen verursachen können, wenn sie in Kontakt mit Flammen und Funken kommen. Nie Ausbesserungen auf eine Batterie aus der und im Amt. Keine Geräte oder Metall Geburten auf die Batterie. Säuberungen erhalten und trocken die Batterien; die Verbindungen müssen wieder mit fettem antiacido oder vasellina bedeckt werden. Gut Kur, daß sie vaschet-zu von E i n s c h r ä n k u n g Säuberung wird erhalten.

NORMAS DE SEGURIDAD BATERÍAS. Hace falta siempre recordar que las baterías engendran gas que pueden provocar estallidos si vienen en contacto con llamas y chispas. No ejecutes nunca reparaciones sobre una batería que y actual. No apoyes utensilios o partes metálicos sobre la batería. Mantener limpienes y secas las baterías; los enlaces tendrán que ser revestidos con gordo antiácido o vasellina. Tenerlas cura que vaschet-a de contención sea mantenido limpión.

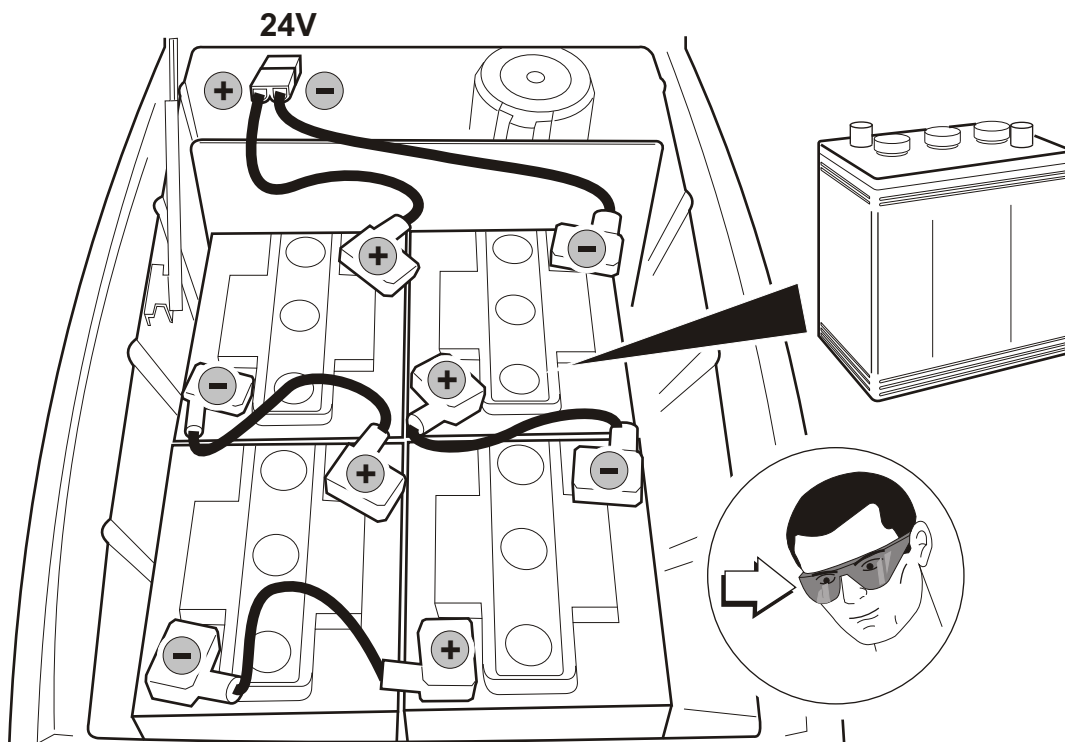

500.250.1
(4x6V 240 Ah)

Batterie tubolari
Batteries (tubular)
Batteries tubulaires
Röhrenförmige Batterien
Baterías tubulares

500.250.3
(4x6V 240 Ah)

Batterie piastra piana
Batteries (plate plane)
Batteries plaque plate
Batterien flache Platte
Baterías lámina llana

NEL CASO DI PERDITA DI ACIDO DALLE BATTERIE: sostituire la batteria con la perdita rispettando le polarità ed i collegamenti sopra indicati. Per questa operazione usare dei guanti di gomma, grembiule ed occhiali per proteggere la pelle e gli occhi.

IN CASE OF ACID LOSS FROM THE BATTERIES: replace the battery with the loss respecting the polarities and the connections shown above. For this operation use rubber gloves, apron and glasses to protect the skin and the eyes.

DANS LE CAS DE PERTE D'ACIDE DES BATTERIES: remplacer la batterie avec la perte en respectant les polarités et les liaisons sur indiqués. Pour cette opération utiliser des gants de gomme, tablier et lunettes pour protéger la peau et les yeux.

IN DER FALL VON VERLUST AUS SÄURE VON DEN BATTERIEN: die Batterie mit dem Verlust die Polaritäten und die Verbindungen auf geeignete beachtend. Für diese Operation von den Gummihandschuh, Kittel und Brillen benutzen um die Haut und die Augen zu schützen.

EN EL CASO DE PÉRDIDA DE ÁCIDO DE LAS BATERÍAS: reemplazar la batería con la pérdida respetando las polaridades y los enlaces sobre indicado. Por esta operación usar de los guantes de goma, delantal y gafas para proteger la piel y los ojos.



DICHIARAZIONE DI CONFORMITÀ: la
DECLARATION OF CONFORMITY: (company name)
DECLARATION DE CONFORMITE: la
ÜBEREINSTIMMUNGSERKLÄRUNG
DECLARACION DE CONFORMIDAD

OMM lavapavimenti Via Cantu' 8/10
Cinisello Balsamo (MI) - ITALY
Tel. ++39.02.612.83.80 - Fax ++39.02.66.59.49.00

dichiara sotto la propria esclusiva responsabilità che la/le macchina/e nuova/e:
declares under its own responsibility that the new machine/s:
déclare sous sa responsabilité exclusivement que le/les machine/s nouveau/s:
erklärt unter ausschließlicher eigener Verantwortung, daß die Maschine(n) neu:
declara bajo su propia y exclusiva responsabilidad que la/s máquina/s nueva/s:



560 Rugby

Modello/model/modele/modell/modelo

è/sono conforme/mi alle seguenti norme:
conform/s to the following laws:
est/sont conforme/saux normes:
mit den folgenden Normen übereinstimmen:
está/están conforme/s a las siguientes normas:

EN61000-6-1/2007 EN61000-6-3/2007 EN ISO5349-1/2001
EN ISO5349-2/2001 EN ISO11201/1997

ed inoltre è/sono fabbricata/e nel rispetto delle direttive e/o decreti:
and moreover is/are built according to the directives and/or decrees:
et est/sont fabriquées, en outre, conformément aux directives et/ou décrets:
und daß sie unter Einhaltung folgender Verordnungen und/oder Dekrete hergestellt worden (sind):
y que además ha/han sido fabricada/s en conformidad con las directivas y/o decretos:

2006/42/CE - 89/336/CEE - 73/23/CEE - 98/37/CEE - DPR547 - DPR224

l'amministratore:	CLAUDIO MESCOLI	Firma	Data
executive officer:	CLAUDIO MESCOLI	Signed	Date
l'administrateur:	CLAUDIO MESCOLI	Signature	Date
der Geschäftsführer:	CLAUDIO MESCOLI	Firma	Datum
el administrador:	CLAUDIO MESCOLI	Firma	Fecha





INCONVENIENTE - TROUBLES -	CAUSA - POSSIBLE REASON	RIMEDIO - REMEDIES
La macchina non avanza <i>The machine doesn't move</i>	Batteria scarica <i>The battery is low</i>	Caricare la batteria Verificare gli elementi se opportunamente attrezzati. <i>Charge the battery</i> <i>Check every element of it only if you own the right instrument</i>
	Connettore motore trazione scollegato oppure ossidato <i>The connector of the traction motor is disconnected or oxidized</i>	Controllare connettore <i>Check the connector</i>
	Microinterruttore manico difettoso (uomo a terra) <i>Defective handle microswitch (walk behind machine)</i>	Controllare il micro e/o sostituirlo <i>Check the microswitch and change it</i>
	Carboncini motore trazione ossidati o consumati <i>Motor carbons oxidized or consumed</i>	Pulire o sostituire i carboncini <i>Clean or change the motor carbons</i>
	Scheda trazione malfunzionante <i>Traction electronic card is fault</i>	Sostituire la scheda di trazione dopo aver consultato il tecnico specializzato <i>After contacting the technician change the card</i>
	Micro sedile malfunzionante (uomo a bordo) <i>The seat-microswitch isn't operating properly</i>	Controllare e se nel caso sostituire il micro <i>Check and if it is necessary change the seat-microswitch</i>
	Micro pedale freno premuto (uomo a bordo) <i>Brake pedal (microswitch) pressed (only on ride-on machines)</i>	Rilasciare il freno, controllare il micro e se necessario sostituirlo. <i>Release the brake pedal,</i> <i>Check and if it is necessary change the microswitch</i>
Il piatto spazzole non scende <i>The brushes plate doesn't move on the floor</i>	La macchina non si muove <i>The machine doesn't move</i>	Controllare la centralina di trazione <i>Check the traction card</i>
	Martinetto spazzole in blocco o bruciato <i>The linear actuator is blocked or burned</i>	Controllare regolazione corsa con micro o sostituire il motorino del martinetto <i>Check the microswitches adjustment or change the linear actuator's motor</i>
Le spazzole funzionano ad intermittenza <i>The brushes run and stop repeatedly</i>	Batterie scariche <i>Discharged batteries</i>	Caricare la batteria Verificare gli elementi se opportunamente attrezzati <i>Check the batteries</i> <i>Check every element of it only if you own the right instrument</i>
Le spazzole non girano <i>The brushes don't rotate</i>	Carboncini motore trazione ossidati o consumati <i>Motor carbons oxidized or consumed</i>	Pulire o sostituire i carboncini <i>Clean or change the motor carbons</i>
	Il fusibile è bruciato <i>The fuse is burned</i>	Sostituire il fusibile <i>Change the fuse</i>
	Teleruttore spazzola ossidato o bruciato <i>The brush power switch is oxidized or burned</i>	Ripristinare il teleruttore o sostituirlo <i>Clean the power switch and/or change it</i>
	Micro martinetto non abilita il teleruttore <i>The linear actuator doesn't allow the power switch to operate</i>	Regolare il micro del martinetto <i>Adjust the linear actuator micro switch</i>



INCONVENIENTE - TROUBLES -	CAUSA - POSSIBLE REASON	RIMEDIO - REMEDIES
Il motore di aspirazione non funziona <i>The vacuum motor doesn't work</i>	Teleruttore motore ossidato o bruciato <i>The motor power switch is oxydized or burned</i>	Ripristinare il teleruttore o sostituirlo <i>Clean the power switch and/or change it</i>
	Il fusibile è bruciato <i>The fuse is burned</i>	Sostituire il fusibile <i>Change the fuse</i>
La macchina non aspira l'acqua <i>The scrubber doesn't recover all the water</i>	Serbatoio pieno <i>Recover tank full</i>	Svuotare il serbatoio di recupero <i>Discharge the tank</i>
	Tergipavimento alzato dal pavimento <i>The squeegee is lifted from the floor</i>	Abbassare il tergilavaggio <i>Lower the squeegee to the ground</i>
	Tubo del tergilavaggio o tergilavaggio intasato <i>The squeegee hose is not free inside</i>	Controllare e liberare il tubo e/o il tergilavaggio <i>Check and free the hose from everything is inside</i>
	Filtro motore aspirazione sporco <i>The vacuum motor filter is dirty</i>	Pulire il filtro del motore di aspirazione <i>Clean the filter</i>
	Gomme di asciugatura consumate o tergilavaggio non regolato <i>Squeegee blades consumed or the squeegee itself has to be adjusted</i>	Controllare e/o sostituire le gomme e regolare il tergilavaggio <i>Change the rubbers and adjust properly the squeegee</i>
Il tergilavaggio non scende a terra (Macchine con movimento automatico) <i>The squeegee doesn't move to the floor (Automatic movement machines)</i>	Controllare l'interruttore di aspirazione sul pannello comandi <i>Check the vacuum motor switch on the control panel</i>	Sostituire l'interruttore <i>Change the switch</i>
	Il martinetto non si muove verso il basso <i>The linear actuator doesn't move to the floor</i>	Regolare i micro interruttori <i>Adjust the microswitches</i>
L'acqua pulita non scende <i>The clean water doesn't drop</i>	Filtro dell'acqua pulita intasato <i>The clean water filter dirty</i>	Pulire il filtro dell'acqua pulita all'interno del serbatoio <i>Clean the filter (inside the clean water tank)</i>

Italiano



Solo per Unione Europea (ed AEE),

Questo simbolo indica che il prodotto non può essere eliminato come rifiuto ordinario in conformità alla direttiva WEEE (2002/96/EC) e alla normativa locale vigente. Il prodotto deve essere smaltito presso i centri di raccolta differenziata, ad esempio un distributore autorizzato che applichi il principio del "vuoto a rendere", ovvero il ritiro delle vecchie apparecchiature al momento dell'acquisto delle nuove, o un deposito autorizzato allo smaltimento dei rifiuti derivanti dal disuso delle apparecchiature elettriche ed elettroniche. La gestione impropria di questo tipo di rifiuti può avere un impatto negativo sull'ambiente e sulla salute umana causato dalle sostanze potenzialmente pericolose prodotte dalle apparecchiature elettriche ed elettroniche. Un corretto smaltimento di tali prodotti contribuirà inoltre a un uso efficace delle risorse naturali. Per ulteriori informazioni sui centri di raccolta e recupero dei rifiuti derivanti dal disuso delle apparecchiature, consultare la direttiva WEEE e rivolgersi alle autorità competenti. Un corretto smaltimento di tali prodotti contribuirà inoltre a un uso efficace delle risorse naturali ed eviterà di incorrere nelle sanzioni amministrative di cui all'art. 50 e seguenti del D.Lgs. 22/97.

(AEE: Norvegia, Islanda e Liechtenstein)

English



European union (and EEA) only.

This symbol indicates that this product is not to be disposed of with your household waste, according to the WEEE Directive (2002/96/EC) and your national law. This product should be handed over to a designated collection point, e.g., on an authorized one-for-one basis when you buy a new similar product or an authorized collection site for recycling waste electrical and electronic equipment (EEE). Improper handling of this type of waste could have a possible negative impact on the environment and human health due to the potentially hazardous substances that are generally associated with EEE. At the same time, your cooperation in the correct disposal of this product will contribute to the effective usage of natural resources. For more information about where you can drop off your waste equipment for recycling, please contact your local city office, waste authority, approved WEEE scheme or your household waste disposal service.

(EEA: Norway, Iceland and Liechtenstein)

Français



Union européenne (et EEE) uniquement.

Ce symbole indique que, conformément à la directive DEEE (2002/96/CE) et à la réglementation de votre pays, ce produit ne doit pas être jeté avec les ordures ménagères. Vous devez le déposer dans un lieu de remassage prévu à cet effet, par exemple, un site de collecte officiel des équipements électriques et électroniques (EEE) en vue de leur recyclage ou un point d'échange de produits autorisé qui est accessible lorsque vous faites l'acquisition d'un nouveau produit de même type que l'ancien. Toute déviation par rapport à ces recommandations d'élimination de ce type de déchet peut avoir des effets négatifs sur l'environnement et la santé publique car ces produits EEE contiennent généralement des substances qui peuvent être dangereuses. Parallèlement, votre entière coopération à la bonne mise au rebut de ce produit favorisera une meilleure utilisation des ressources naturelles. Pour obtenir plus d'informations sur les points de collecte des équipements à recycler, contactez votre mairie, le service de collecte des déchets, le plan DEEE approuvé ou le service d'enlèvement des ordures ménagères.

(EEE: Norvège, Islande et Liechtenstein)

Deutsch



Nur Europäische Union (und EWR).

Dieses Symbol weist darauf hin, dass dieses Produkt gemäß Richtlinie über Elektro- und Elektronik-Altgeräte (2002/96/EG) und nationalen Gesetzen nicht über den Hausmüll entsorgt werden darf. Dieses Produkt muss bei einer dafür vorgesehenen Sammelstelle abgegeben werden. Dies kann z. B. durch Rückgabe beim Kauf eines ähnlichen Produkts oder durch Abgabe bei einer autorisierten Sammelstelle für die Wiederaufbereitung von Elektro- und Elektronik-Altgeräten geschehen. Der unsachgemäße Umgang mit Altgeräten kann aufgrund potentiell gefährlicher Stoffe, die häufig in Elektro- und Elektronik-Altgeräten enthalten sind, negative Auswirkungen auf die Umwelt und die menschliche Gesundheit haben. Durch die sachgemäße Entsorgung dieses Produkts tragen Sie außerdem zu einer effektiven Nutzung natürlicher Ressourcen bei. Informationen zu Sammelstellen für Altgeräte erhalten Sie bei Ihrer Stadtverwaltung, dem öffentlich-rechtlichen Entsorgungsträger, einer autorisierten Stelle für die Entsorgung von Elektro- und Elektronik-Altgeräten oder Ihrer Müllabfuhr.

(EWR: Norwegen, Island und Liechtenstein)

Español



Sólo para la Unión Europea (y la EEA).

Este símbolo indica que este producto no debe desecharse con los desperdicios del hogar, de acuerdo con la directiva WEEE (2002/96/EC) y con la legislación nacional. Este producto debería entregarse en uno de los puntos de recogida designados, como por ejemplo, intercambiando uno por otro al comprar un producto similar o entregándolo en un lugar de recogida autorizado para el reciclado de equipos electrónicos (EEE). La manipulación inapropiada de este tipo de desechos podría tener un impacto negativo en el entorno y la salud humana, debido a las sustancias potencialmente peligrosas que normalmente están asociadas al EEE. Al mismo tiempo, su cooperación a la hora de desechar correctamente este producto contribuirá a la utilización efectiva de los recursos naturales. Para más información acerca de dónde puede desechar el equipo para su reciclado, póngase en contacto con las autoridades locales, con las autoridades encargadas de los desechos, con un plan WEEE autorizado o con el servicio de recogida de basuras para hogares.

(EEA: Noruega, Islandia y Liechtenstein)